



Shanghai Michigan Mechanical Co Ltd

上海密歇根机械有限公司

上海市平凉路 1090 号 424 室

Tel: 86-021 35 31 04 35 Fax: 86-021 23 02 50 78 Website: www.shsmm.com

Equipment List for reference

CNC Lathe

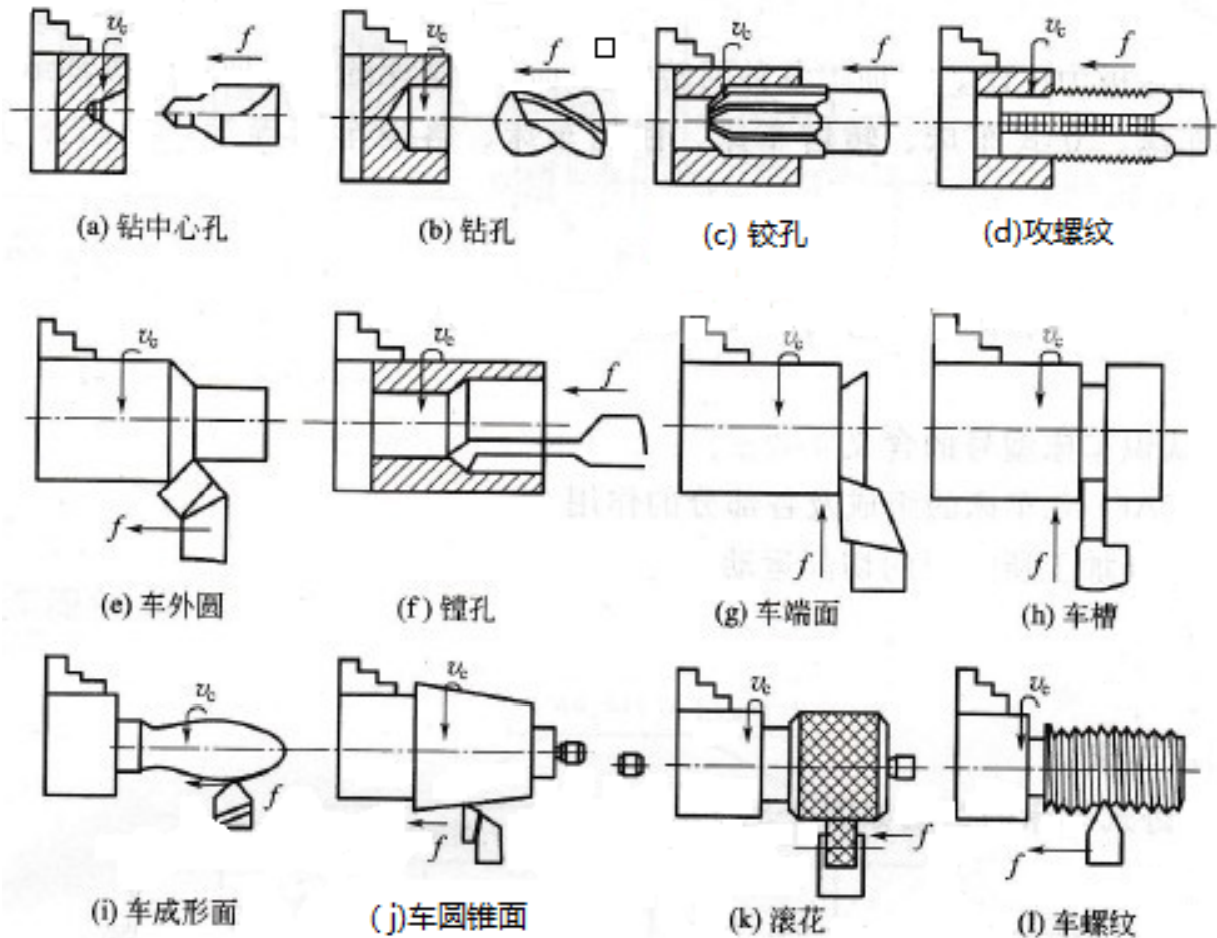

MODEL	BRAND	Spindle stroke X, mm	Spindle stroke Z, mm	Max Diameter, mm
CKD6150A	DMTG	280	2000	Φ400
DL-40M	DMTG	436	3000	Φ800
CKA61100M	DMTG	520	3000~8000	Φ1000
CKG 35	DMTG	520	1250	Φ355

Machining Center MILL+DRILL+TAP+BORE

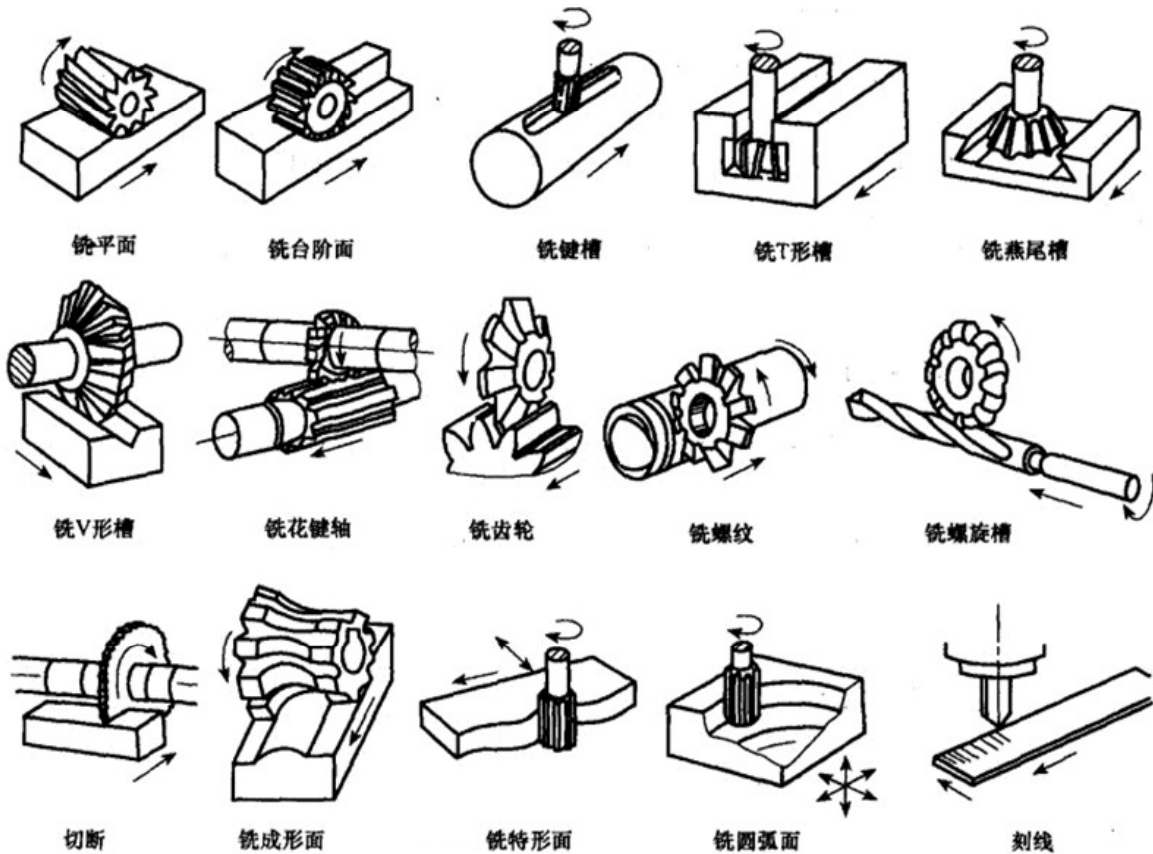

铣床的加工范围



图2 螺纹铣削

CNC Machining Center

MODEL	BRAND	Spindle stroke X, mm	Spindle stroke Y, mm	Spindle stroke Z, mm	ATC
HDA63	DMTG	1000	800	900	24
VDF1800	DMTG	1850	800	762	24

CNC Horizontal Machining Center

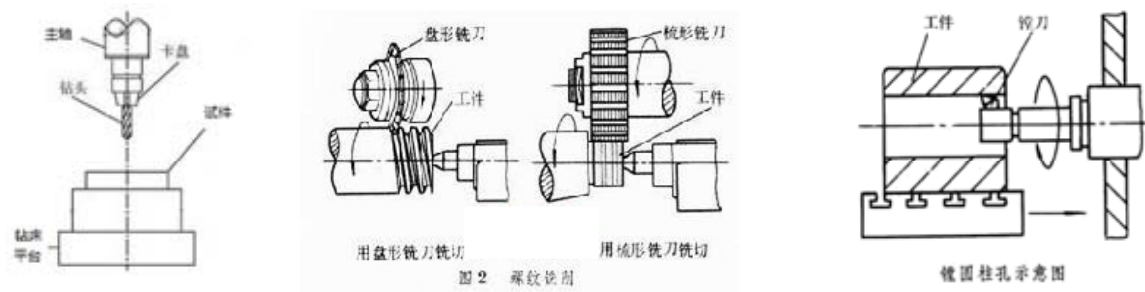
MODEL	BRAND	Spindle stroke X, mm	Spindle stroke Y, mm	Spindle stroke Z, mm	Table
NH4000	Mori Seik	560	560	630	400x400
NH5000	Mori Seik	730	730	850	500x500
NH6300	Mori Seik	1050	900	980	630x630

CNC Cylindrical Grinder 外圆磨

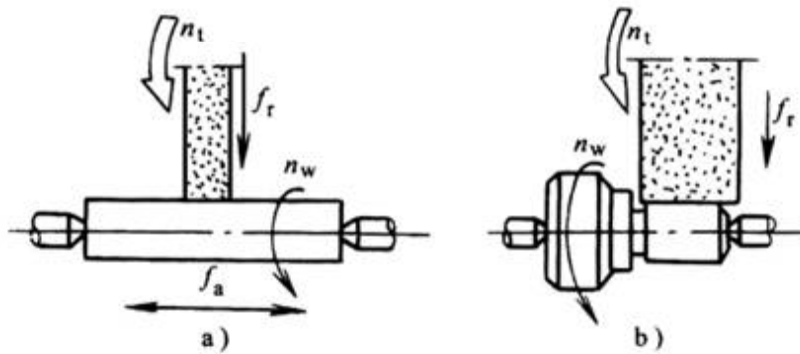

外圆磨床的磨削方法

MODEL	BRAND	Diameter,max,mm		work piece weight max, kg	Center Height mm	Accuracy mm
		Rotation	Wheel			
MK1420	Shanghai Electric	Φ200	500/750	50	125	0.001
H234	Shanghai Electric	Φ320	2000	70kg	250	0.001

CNC Surface Grinder 平面磨

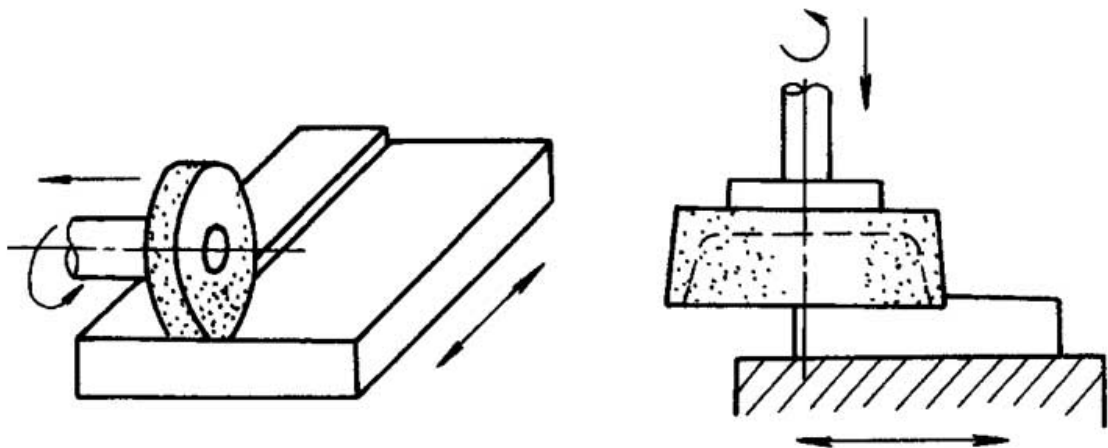

(a) 周磨法

(b) 端磨法

Model	Brand	Worktable Size	Work Piece Size	Worktable Trave	Accuracy mm
		L*W,mm	L×W×H,max,mn	longitudinal	
MB7150H (MC100H)	Shanghai Electric	500*1000	500*1000*650	1080,max,mm	0.005

Milling/Hobbing

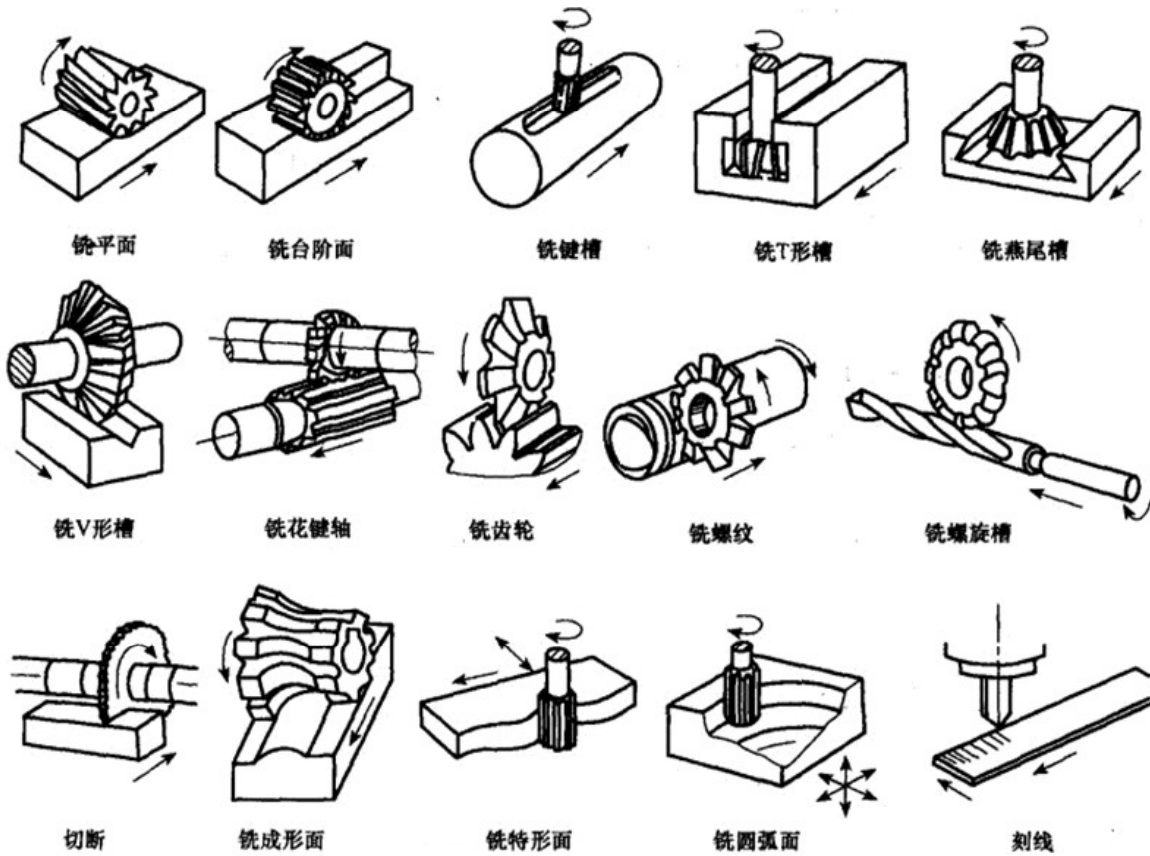

铣床的加工范围

MODEL	BRAND	Rotation Diameter length,max,mm	Module max,mm	Spindle stroke max,mm	Rotary table load max,kg
YK5180	Shanghai Electric	Φ600	10	200	1,100
ZFWZ 3150/30	Shanghai Electric	Φ3800	30	1250	8,000
RMX3200	Kesel	Φ7800	40	unknown	17,000
Y31800A	Zhong yuan	Φ8000	40	unknown	unknown

Profile Grinding Machines

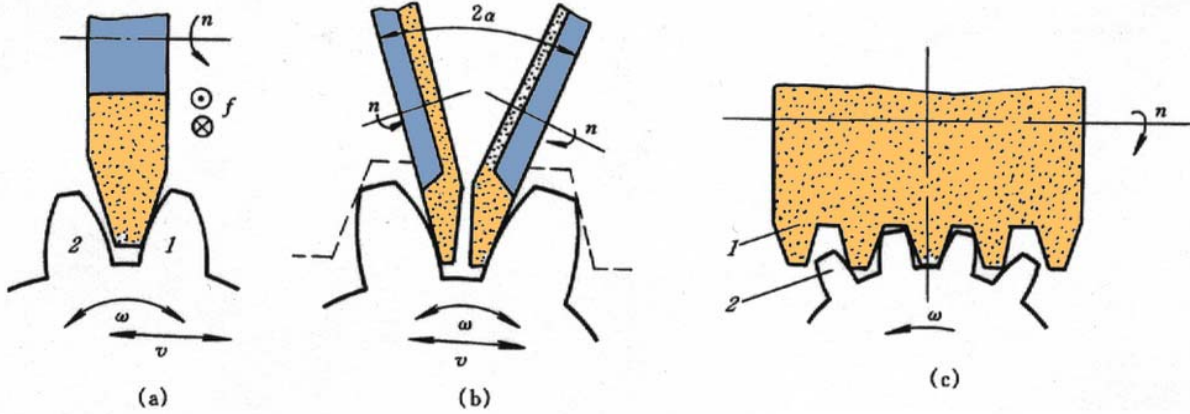

MODEL	BRAND	Outside Diameter of gear, max,mm	Profile height max,mm	Axial stroke length max,mm	Grind wheel Diameter,max,mm
HELIX 400	HOFLER	400	35	260	400
PAPID 800	HOFLER	400	80	1500	400
ZE 800	NILES	800	55	600	560
ZP12	NILES	1250	100	1500	835
ZP24	NILES	2400	100	1800	1500

Sand Casting Process 砂铸工艺

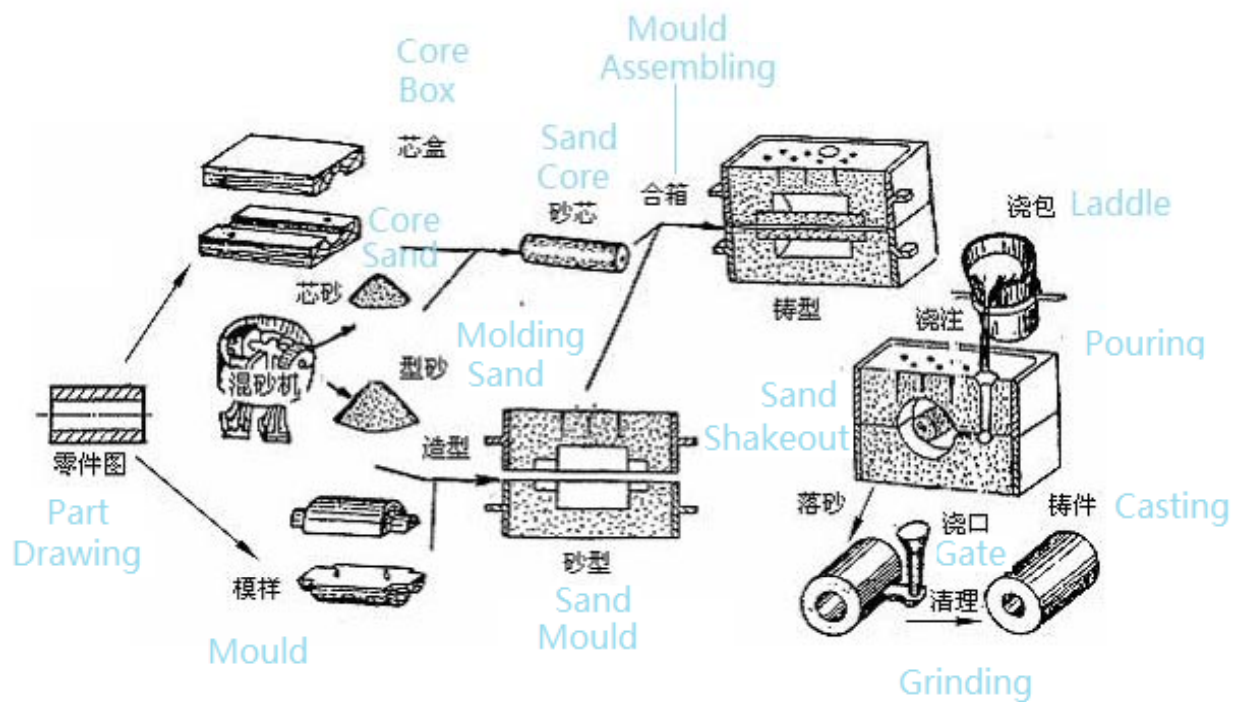

Sand storage, mixing, transportation system 砂子存储、混合、运输系统

Single girder bridge crane 单梁桥式起重机 (配模、起重)

Lifting electromagnet 起重电磁铁 (吸盘&称重)

Medium frequency furnace, Arc furnace 中频电炉, 电弧炉 (熔炼钢水)

Ladle and Ladle baking device 浇包和钢包烘烤器

Infrared temperature measuring instrument & Liquid steel temperature measuring instrument 测温仪

Shot Blast & Grinding System 抛丸、打磨

Water/Oil Quench System 水/油淬系统

Hydraulic Press 液压矫正设备

Lost Wax Casting Process 失蜡铸造工艺

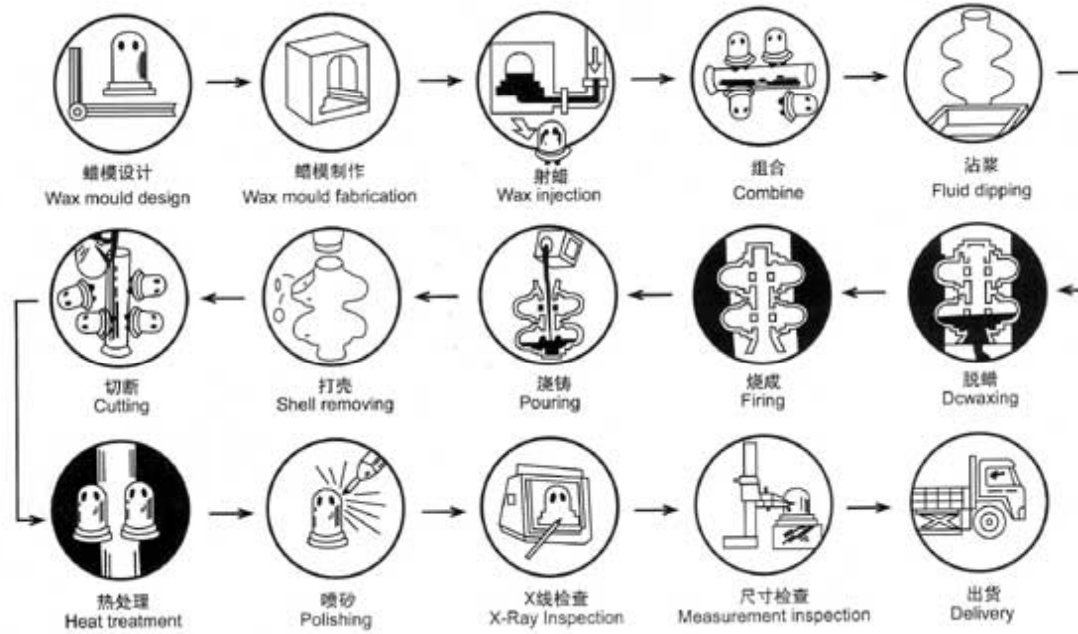

Wax storage, injection and recycling system 蜡的存储、注射、回收系统

Lifting electromagnet 起重电磁铁 (吸盘&称重)

Medium frequency furnace 中频电炉 (熔炼钢水)

Ladle and Ladle baking device 浇包和钢包烘烤器

Infrared temperature measuring instrument & Liquid steel temperature measuring instrument 测温仪

Shot Blast & Grinding System 抛丸、打磨

Water/Oil Quench System 水/油淬系统

Hydraulic Press 液压矫正设备



Spectrometer(WJ,DF)



Hardness (HB, HRC, HV)(WJ,DF)



Metallographic Examination (WJ)



Tensile testing machine(WJ,DF)



Impact Test(WJ,DF)



Ultrasonic flaw detector (WJ)



Magnetic Flux Detector

Outsource when required

X-Ray Flaw Detector



Height indicator



Roughness



Coordinate Measuring Machining

CMM



Coating thickness



Caliper



Micrometer

CAD/CAM & Technology
Model-based definition
Solidworks 2014
AutoCAD 2014